



RAYSTAR

RAYSTAR Optronics, Inc.  
曜凌光電股份有限公司



# 曜凌光電股份有限公司 Raystar Optronics, Inc.

42881台中市大雅區科雅路25號5樓  
5F, No. 25, Keya Road, Daya Dist., Taichung City 42881, Taiwan  
T : +886-4-2565-0761 | F : +886-4-2565-0760  
sales@raystar-optronics.com | www.raystar-optronics.com

## RFF700A9-AWW-DNB

### SPECIFICATION

CUSTOMER:

<b>APPROVED BY</b>	
<b>PCB VERSION</b>	
<b>DATE</b>	

FOR CUSTOMER USE ONLY

<b>SALES BY</b>	<b>APPROVED BY</b>	<b>CHECKED BY</b>	<b>PREPARED BY</b>

Release DATE:

TFT Display Inspection Specification: <https://www.raystar-optronics.com/download/products.htm>  
Precaution in use of TFT module: <https://www.raystar-optronics.com/download/declaration.htm>

## Revision History

VERSION	DATE	REVISED PAGE NO.	Note
0 A	2021/02/20 2021/07/09		First issue Modify Contour drawing & Storage Temperature

RAYSTAR OPTRONICS

# Contents

1. Module Classification Information
2. Summary
3. General Specifications
4. Interface
5. Contour Drawing
6. Block Diagram
7. Absolute Maximum Ratings
8. Electrical Characteristics
9. DC Characteristics
10. AC Characteristics
11. Optical Characteristics
12. Reliability
13. Touch Panel Information
14. Other

# 1.Module Classification Information

<b>R</b>	<b>F</b>	<b>F</b>	<b>70</b>	<b>0A9</b>	<b>-</b>	<b>A</b>	<b>W</b>	<b>W</b>	<b>-</b>	<b>D</b>	<b>N</b>	<b>B</b>
1	2	3	4	5	-	6	7	8	-	9	10	11

Item	Description	
1	R : Raystar Optronics Inc.	
2	Display Type : F→TFT Type, J→ Custom TFT	
3	Solution: A: 128x160    B:320x234    C:320x240    D:480x234    E:480x272 F:800x480    G:640x480    H:1024x600    I:320x480    J:240x320 K:1280x800    L:240x400    M:1024x768    N:128x128    O:480x800 P:640x320    Q:800x600    S:480x128    T:800x320	
4	Display Size : 7.0" TFT	
5	Version Code.	
6	Model Type: A : TFT LCD E : TFT+FR+CONTROL BOARD J : TFT+FR+A/D BOARD N : TFT+FR+A/D BOARD+CONTROL BOARD S : TFT+FR+POWER BOARD (DC TO DC) 1 : TFT+CONTROL BOARD	6 : TFT+FR H : TFT+D/V BOARD I : TFT+FR+D/V BOARD B : TFT+POWER BD
7	Polarizer Type, Temperature range, View direction	I→Transmissive, W. T, 6:00 ;    C→Transmissive, N. T, 6:00 L→Transmissive, W.T,12:00 ;    F→Transmissive, N.T,12:00 Y→Transmissive,W.T, IPS TFT ; W→Transmissive, Super W.T, IPS TFT A→Transmissive, N.T, IPS TFT Z→Transmissive, W.T, O-TFT R→Transmissive, Super W.T, O-TFT N→Transmissive, Super W.T, 6:00; Q→Transmissive, Super W.T, 12:00 V→Transmissive, Super W.T, VA TFT
8	Backlight	W : LED, White                      H : LED, High Light White F : CCFL, White
9	Driver Method	D: Digital    A: Analog    L : LVDS    M:MIPI
10	Interface	N : without control board    A : 8Bit    B : 16Bit S:SPI Interface    R: RS232    U:USB    I: I2C
11	TS	N : Without TS    S : resistive touch panel C : capacitive touch panel capacitive touch panel (G-F-F) G : capacitive touch panel(G-G)    B : CTP+GG+USB

RAYSTAR OPTRONICS

## 2.Summary

The RF70 is a 7-inch LCD Cell with thin film transistors as active elements and contains 800 (H) X 480 (V) pixels. Each pixel is divided into red, green and blue dot, which are arranged in vertical stripe. The cell is normally black mode, and can be applied to the transmission type display. Backlight unit (BLU) and circuit board for the cell are not built in.

RAYSTAR OPTRONICS

---

### 3. General Specifications

- Size: 7.0 inch
- Dot Matrix: 800 x RGB x 480(TFT) dots
- Module dimension: 165.8 (W) x 106.61 (H) x 8.9(D) mm
- Active area: 152.40 x 91.44 mm
- Pixel pitch: 0.1905 x 0.1905 mm
- LCD type: TFT, Normally Black, Transmissive
- View Direction: 80/80/80/80
- TFT Interface: 24-bit RGB
- TFT Driver IC: HX8249-A + HX8678-C or Equivalent
- Aspect Ratio: 15:9
- Backlight Type: LED, Normally White
- CTP IC: ILI2511 or equivalent
- CTP Interface: USB (I2C available)
- CTP FW Version: 6.0.0.0.0.0.1
- With /Without TP: With CTP
- Surface: Glare

\*Color tone slight changed by temperature and driving voltage.



## 4.Interface

### 4.1. LCM PIN Definition

Pin	Symbol	Function	Remark
1-4	NC	No connection	
5	GND	Power Ground	
6	NC	No connection	
7	VCC	Power voltage	
8	MODE	Input timing mode selection.	
		<b>MODE</b>	<b>Function</b>
		0	DE only
		1	HS+VS
		<b>Note</b>	
		-	
		Default	
9	DE	Data enable signal for TTL mode.	
10	VS	Vertical sync input	
11	HS	Horizontal sync input	
12	B7	Blue data(MSB)	
13	B6	Blue data	
14	B5	Blue data	
15	B4	Blue data	
16	B3	Blue data	
17	B2	Blue data	
18	B1	Blue data	
19	B0	Blue data(LSB)	
20	G7	Green data(MSB)	
21	G6	Green data	
22	G5	Green data	
23	G4	Green data	
24	G3	Green data	
25	G2	Green data	
26	G1	Green data	
27	G0	Green data(LSB)	
28	R7	Red data(MSB)	
29	R6	Red data	
30	R5	Red data	
31	R4	Red data	

32	R3	Red data										
33	R2	Red data										
34	R1	Red data										
35	R0	Red data (LSB)										
36	GND	Power Ground										
37	DCLK	Sample clock										
38	GND	Power Ground										
39	L/R	Horizontal shift direction (source output) selection. <table border="1"> <thead> <tr> <th>L/R</th> <th>Source output sequence and data order</th> <th>Note</th> </tr> </thead> <tbody> <tr> <td>1</td> <td>Left to right</td> <td>Default</td> </tr> <tr> <td>0</td> <td>Right to left</td> <td>-</td> </tr> </tbody> </table>	L/R	Source output sequence and data order	Note	1	Left to right	Default	0	Right to left	-	Note1
L/R	Source output sequence and data order	Note										
1	Left to right	Default										
0	Right to left	-										
40	U/D	Vertical shift direction (gate output) selection. <table border="1"> <thead> <tr> <th>U/D</th> <th>Function</th> <th>Note</th> </tr> </thead> <tbody> <tr> <td>1</td> <td>Top→bottom</td> <td>Default</td> </tr> <tr> <td>0</td> <td>Bottom→top</td> <td>-</td> </tr> </tbody> </table>	U/D	Function	Note	1	Top→bottom	Default	0	Bottom→top	-	Note2
U/D	Function	Note										
1	Top→bottom	Default										
0	Bottom→top	-										
41	NC	No connection										
42	NC	No connection										
43	NC	No connection										
44	RESET	Reset pin. The chip is in reset state when RESETB=0.										
45	NC	No connection										
46	NC	No connection										
47	DITHB	STBYB Standby mode setting pin. The chip is in standby mode when STBYB=0.										
48	GND	Power Ground										
49	NC	No connection										
50	NC	No connection										

Note 1: Selection of scanning mode

Setting of scan control input		Scanning direction
U/D	L/R	
1	1	Top to Bottom, left to right
1	0	Top to Bottom, right to left
0	0	Bottom to Top, right to left
0	1	Bottom to Top, left to right

Note 2: Definition of scanning direction.

Refer to the figure as below:

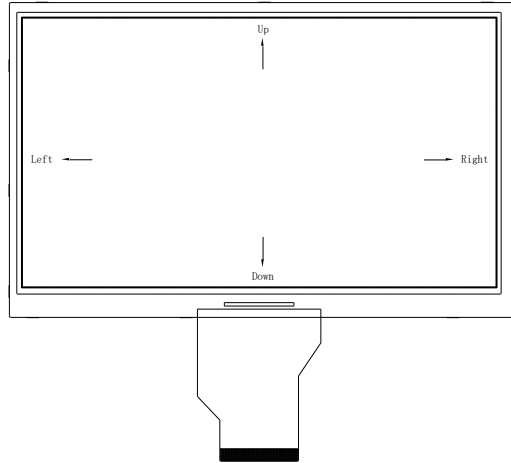

#### 4.2. Backlight PIN Definition

Pin	Symbol	Description
1	VLED+	Red, LED_ Anode
2	VLED-	Black, LED_ Cathode

#### 4.3. CTP PIN Definition

Pin	Symbol	Function	Remark
1	USB_VSS	System ground	
2	USB_VDD 5V	Power supply	
3	USB_D+	Data +	
4	USB_D-	Data -	
5	VSS	System ground	
6	SDA	I2C data input and output	
7	SCL	I2C clock input	
8	RST	External Reset, Low is active	
9	INT	External interrupt to the host	
10	VDDT 3.3	Power supply	

Note: Interface can support both USB and I2C,USB is main function

# 5. Contour Drawing

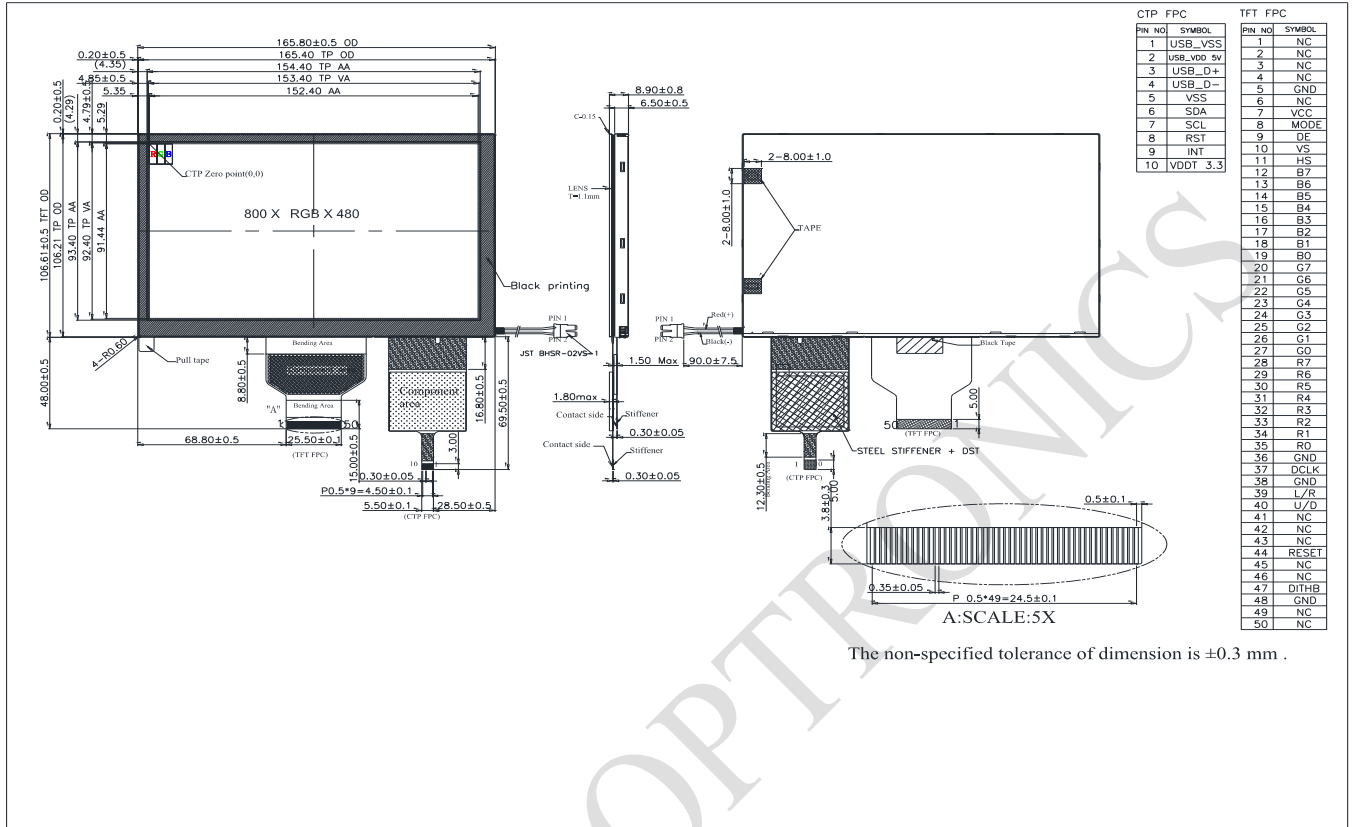

## 6. Block Diagram

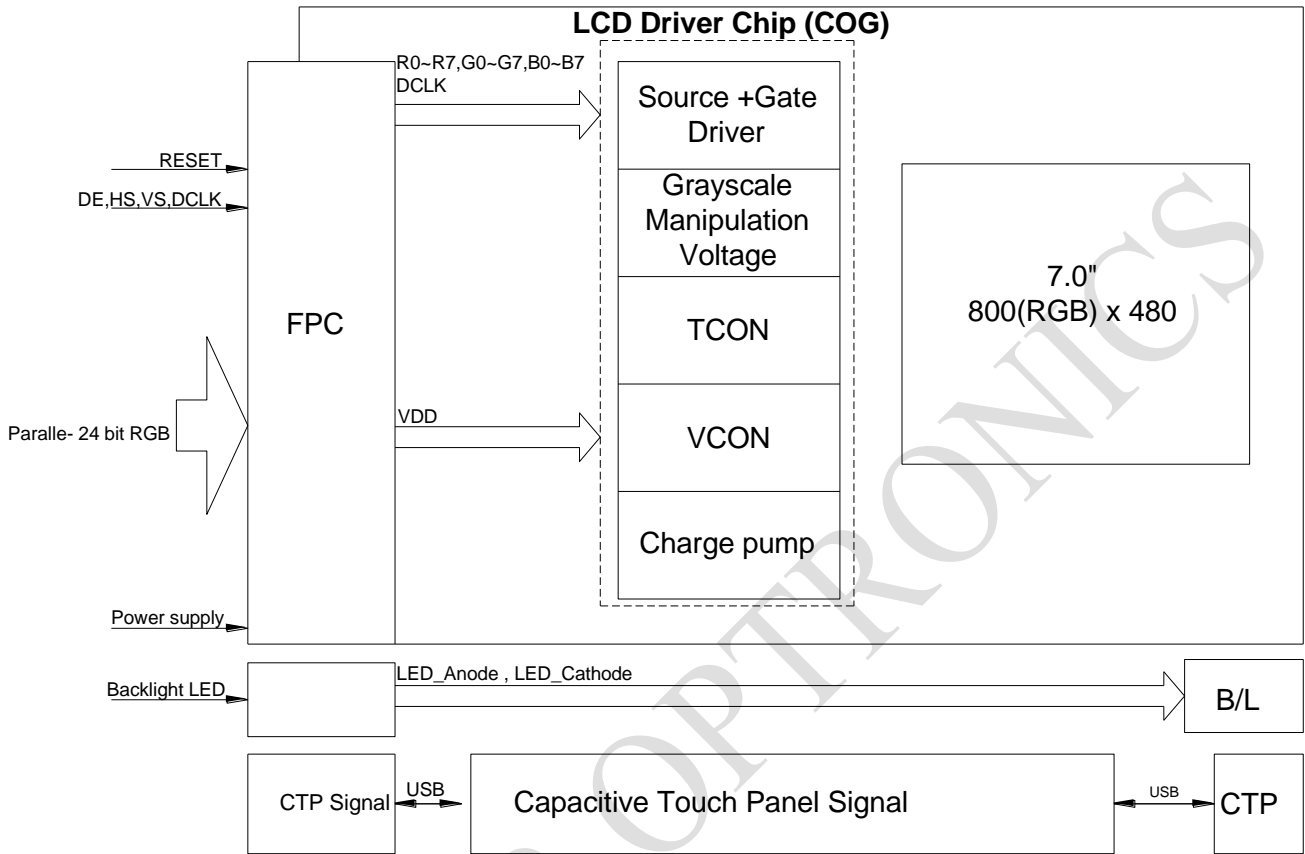

## 7. Absolute Maximum Ratings

Item	Symbol	Min	Typ	Max	Unit
Operating Temperature	TOP	-30	—	+80	°C
Storage Temperature	TST	-40	—	+85	°C

Note: Device is subject to be damaged permanently if stresses beyond those absolute maximum ratings listed above

1. Temp.  $\leq 60^{\circ}\text{C}$ , 90% RH MAX. Temp.  $> 60^{\circ}\text{C}$ , Absolute humidity shall be less than 90% RH at  $60^{\circ}\text{C}$

RAYSTAR OPTRONICS

## 8. Electrical Characteristics

### 8.1. Operating conditions

Item	Symbol	Min	Typ	Max	Unit	Note
Supply Voltage	V <sub>cc</sub>	2.7	3.3	3.6	V	
Current of power supply	I <sub>cc</sub>	—	101	150	mA	V <sub>cc</sub> =3.3V
Supply CTP	USB_VDD 5V	4.4	5.0	5.5	V	USB type
	I <sub>VDD 5V</sub>	—	83.6	126	mA	

### 8.2. LED driving conditions

Parameter	Symbol	Min	Typ	Max	Unit	Remark
LED current	—	—	360	—	mA	
LED voltage	V <sub>LED+</sub>	8.1	9.3	10.2	V	Note 1
LED Life Time	—	40000	—	—	Hr	Note 2,3,4

Note 1 : There are 1 Groups LED

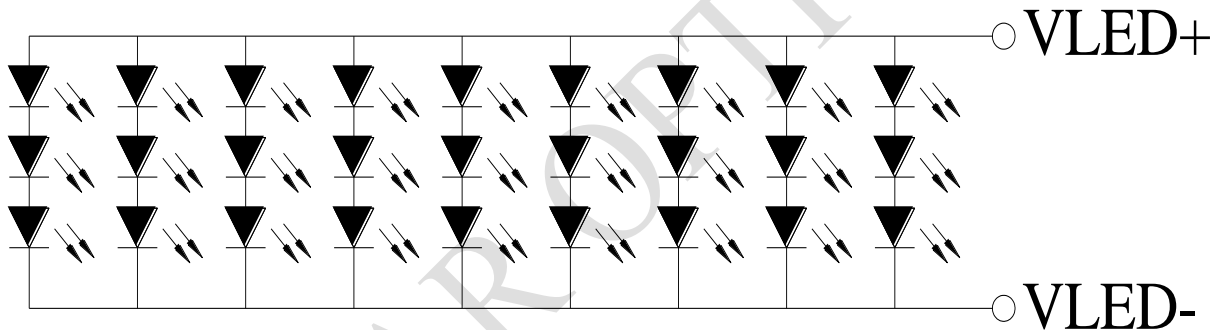

## CIRCUIT DIAGRAM

Note 2 : Ta = 25 °C

Note 3 : Brightness to be decreased to 50% of the initial value

Note 4 : The single LED lamp case

## 9.DC Characteristics

Parameter	Symbol	Rating			Unit	Condition
		Min	Typ	Max		
Low level input voltage	$V_{IL}$	0	-	0.3VCC	V	
High level input voltage	$V_{IH}$	0.7VCC	-	VCC	V	

RAYSTAR OPTRONICS



## 10.AC Characteristics

### 10.1. Parallel SYNC mode RGB input timing table

Parameter	Symbol	Values			Unit	Remark
		Min.	Typ.	Max.		
DCLK frequency	FDCLK	25.2	27.2	30.5	MHz	
Horizontal line	th	856	860	920	DCLK	
Horizontal valid data	thd	800			DCLK	
Hsync pulse width	thpw	1	2	100	DCLK	
Hsync back width	thbp	5	16	101	DCLK	
Hsync front width	thfp	19	44	115	DCLK	
Vertical valid data	tvd	480			H	
Vsync pulse width	tvpw	1	2	66	H	
Vsync back width	tvbp	5	5	67	H	
Vsync front width	tvfp	5	43	67	H	
Vertical field	tv	490	528	552	H	

## 10.2. Input Clock and Data Timing Diagram

- Horizontal

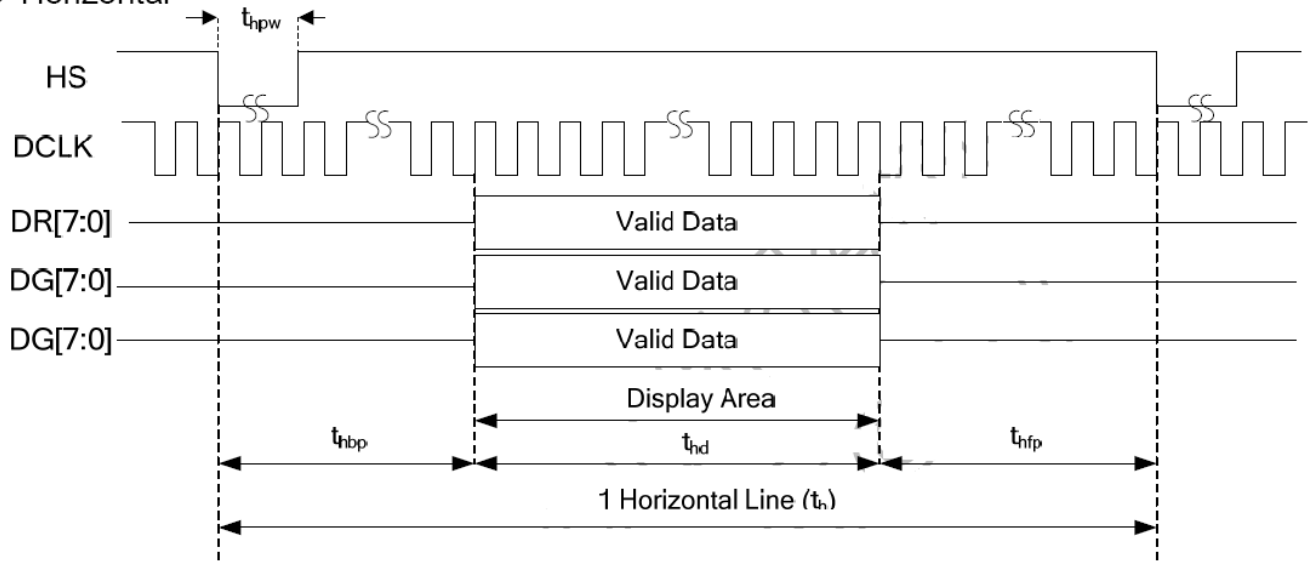

Fig1. Horizontal input Timing at Sync mode

- Vertical

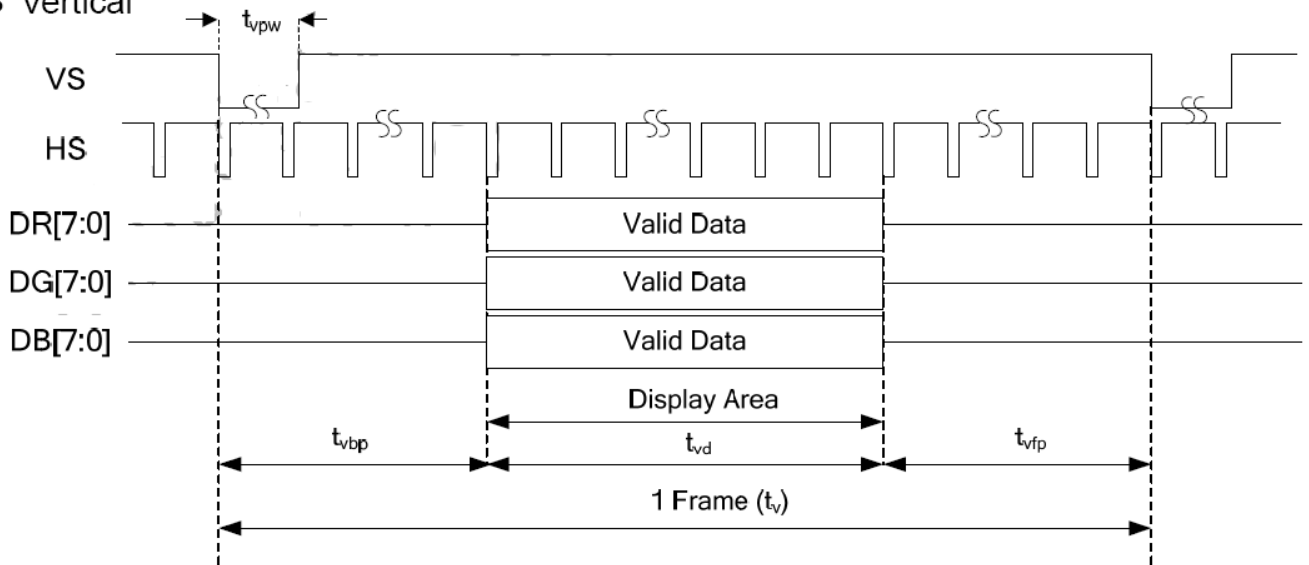

Fig.2. Vertical input Timing at Sync mode

## 11. Optical Characteristics

Item	Symbol	Condition.	Min	Typ.	Max.	Unit	Remark	
Response time	Tr+ Tf	$\theta=0^\circ$ 、 $\phi=0^\circ$	-	25	35	ms	Note 3	
Contrast ratio	CR	At the center point of AA	800	1000	-	-	Note 4	
Color Chromaticity	White	Wx	$\theta=0^\circ$ 、 $\phi=0$	0.26	0.31	0.36	-	Note 2,6,7
		Wy		0.28	0.33	0.38	-	
Viewing angle	Hor.	$\Theta R$	CR $\geq 10$	70	80	-	Deg.	Note 1
		$\Theta L$		70	80	-		
	Ver.	$\Phi T$		70	80	-		
		$\Phi B$		70	80	-		
Brightness	-	-	300	400	-	cd/m <sup>2</sup>	Center of display	
Uniformity	(U)		75	-	-	%	Note5	

Ta=25±2°C , IL=360mA

Note 1: Definition of viewing angle range

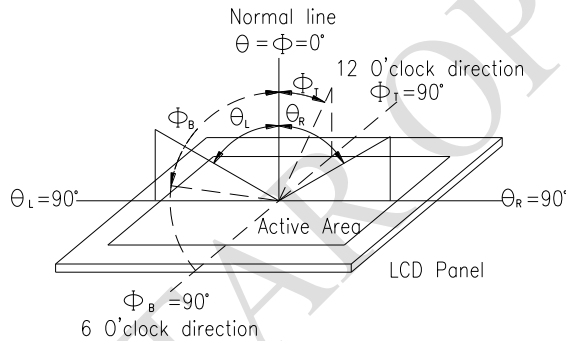

Fig 11.1. Definition of viewing angle

Note 2: Test equipment setup:

After stabilizing and leaving the panel alone at a driven temperature for 10 minutes, the measurement should be executed. Measurement should be executed in a stable, windless, and dark room. Optical specifications are measured by Topcon BM-7or BM-5 luminance meter 1.0° field of view at a distance of 50cm and normal direction.

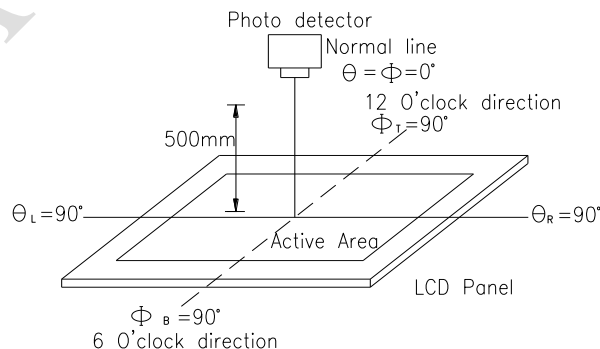
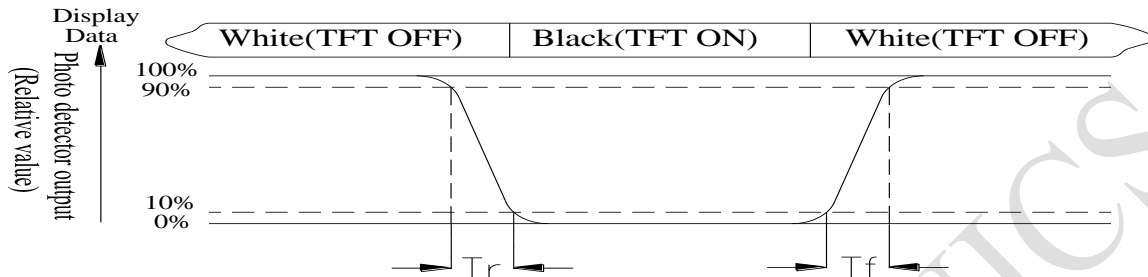

Fig 11.2. Optical measurement system setup

Note 3: Definition of Response time:

The response time is defined as the LCD optical switching time interval between “White” state and “Black” state. Rise time,  $T_r$ , is the time between photo detector output intensity changed from 90% to 10%. And fall time,  $T_f$ , is the time between photo detector output intensity changed from 10% to 90%



Note 4: Definition of contrast ratio:

The contrast ratio is defined as the following expression.

$$\text{Contrast ratio (CR)} = \frac{\text{Luminance measured when LCD on the "White" state}}{\text{Luminance measured when LCD on the "Black" state}}$$

Note 5: Definition of Luminance Uniformity

Active area is divided into 9 measuring areas (Refer Fig. 8.3). Every measuring point is placed at the center of each measuring area.

Luminance Uniformity (U) =  $L_{\min}/L_{\max} \times 100\%$

L = Active area length

W = Active area width

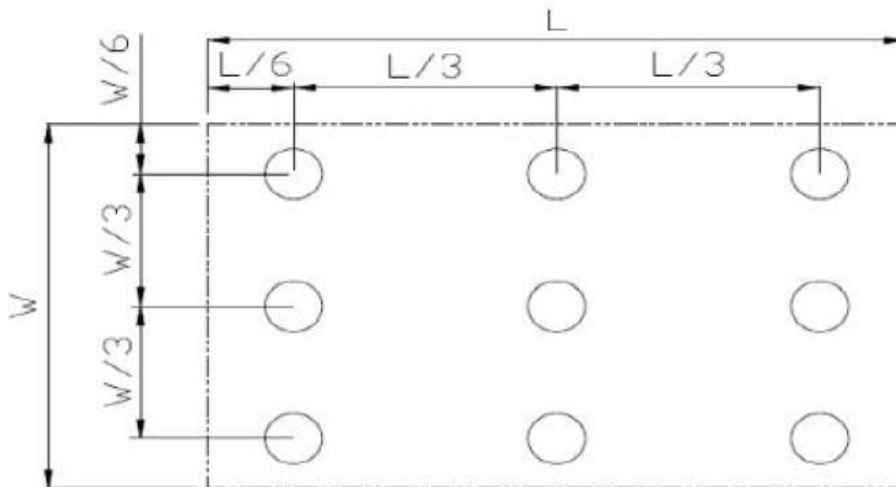

Fig 11.3. Definition of uniformity

Note 6: Definition of color chromaticity (CIE 1931)

Color coordinates measured at the center point of LCD

Note 7: Measured at the center area of the panel when all the input terminals of LCD panel are electrically opened.

## 12. Reliability

Content of Reliability Test (Super Wide temperature, -30°C~80°C)

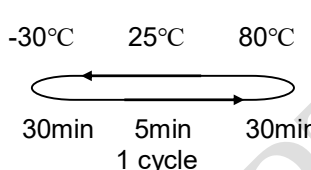
Environmental Test			
Test Item	Content of Test	Test Condition	Note
High Temperature storage	Endurance test applying the high storage temperature for a long time.	85°C 200hrs	2
Low Temperature storage	Endurance test applying the low storage temperature for a long time.	-40°C 200hrs	1,2
High Temperature Operation	Endurance test applying the electric stress (Voltage & Current) and the thermal stress to the element for a long time.	80°C 200hrs	—
Low Temperature Operation	Endurance test applying the electric stress under low temperature for a long time.	-30°C 200hrs	1
High Temperature/ Humidity storage	The module should be allowed to stand at 60°C,90%RH max	60°C,90%RH 96hrs	1,2
Thermal shock resistance	The sample should be allowed stand the following 10 cycles of operation  <div style="text-align: center;">  </div>	-30°C/80°C 10 cycles	—
Vibration test	Endurance test applying the vibration during transportation and using.	Total fixed amplitude : 1.5mm Vibration Frequency : 10~55Hz One cycle 60 seconds to 3 directions of X,Y,Z for Each 15 minutes	3
Static electricity test	Endurance test applying the electric stress to the terminal.	VS=±600V(contact) ,±800v(air), RS=330Ω CS=150pF 10 times	—

Note1: No dew condensation to be observed.

Note2: The function test shall be conducted after 4 hours storage at the normal Temperature and humidity after remove from the test chamber.

Note3: The packing have to including into the vibration testing.

# 13.Touch Panel Information

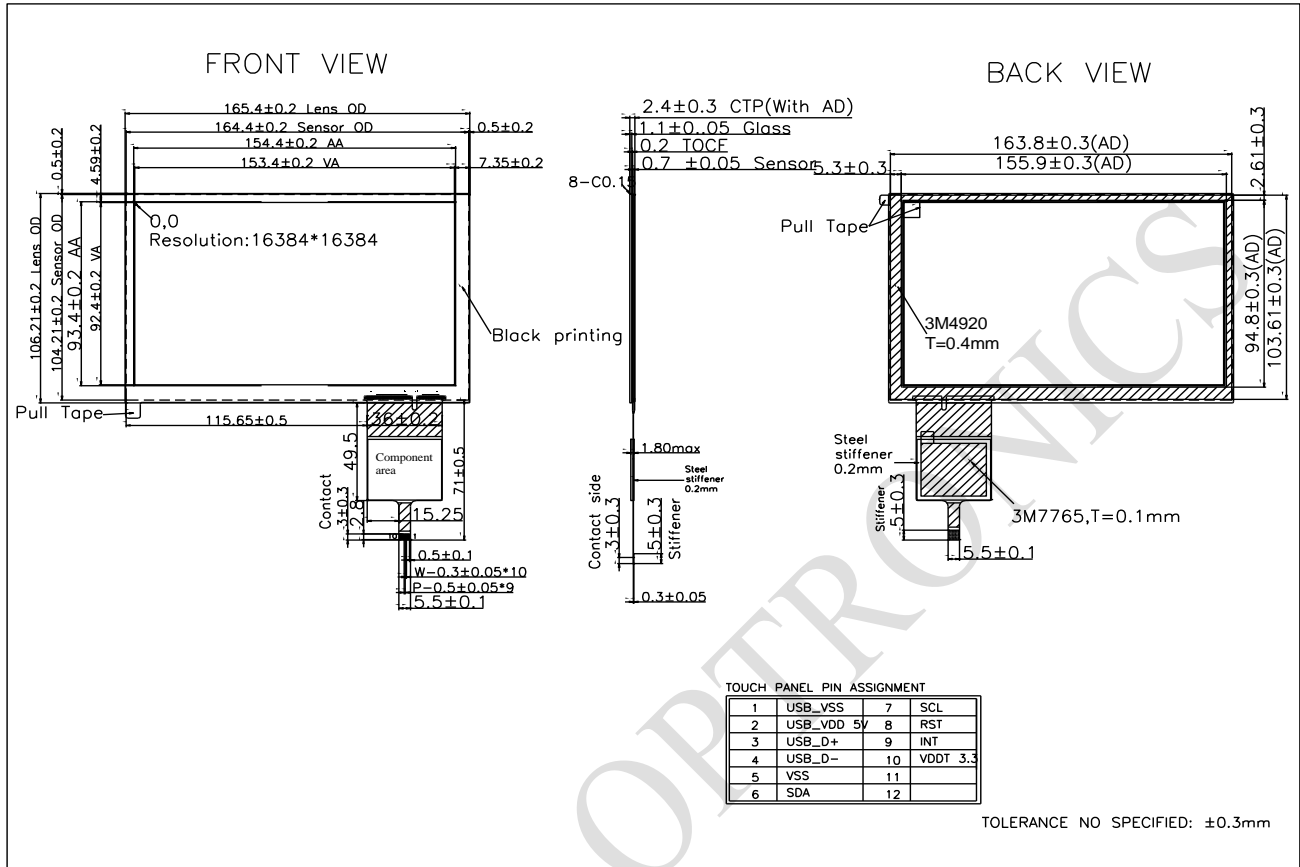

**LCM Sample Estimate Feedback Sheet**

**Module Number :** \_\_\_\_\_

**1 、 Panel Specification :**

1. Panel Type :	<input type="checkbox"/> Pass	<input type="checkbox"/> NG , _____
2. View Direction :	<input type="checkbox"/> Pass	<input type="checkbox"/> NG , _____
3. Numbers of Dots :	<input type="checkbox"/> Pass	<input type="checkbox"/> NG , _____
4. View Area :	<input type="checkbox"/> Pass	<input type="checkbox"/> NG , _____
5. Active Area :	<input type="checkbox"/> Pass	<input type="checkbox"/> NG , _____
6. Operating Temperature :	<input type="checkbox"/> Pass	<input type="checkbox"/> NG , _____
7. Storage Temperature :	<input type="checkbox"/> Pass	<input type="checkbox"/> NG , _____
8. Others :	_____	

**2 、 Mechanical Specification :**

1. PCB Size :	<input type="checkbox"/> Pass	<input type="checkbox"/> NG , _____
2. Frame Size :	<input type="checkbox"/> Pass	<input type="checkbox"/> NG , _____
3. Material of Frame :	<input type="checkbox"/> Pass	<input type="checkbox"/> NG , _____
4. Connector Position :	<input type="checkbox"/> Pass	<input type="checkbox"/> NG , _____
5. Fix Hole Position :	<input type="checkbox"/> Pass	<input type="checkbox"/> NG , _____
6. Backlight Position :	<input type="checkbox"/> Pass	<input type="checkbox"/> NG , _____
7. Thickness of PCB :	<input type="checkbox"/> Pass	<input type="checkbox"/> NG , _____
8. Height of Frame to PCB :	<input type="checkbox"/> Pass	<input type="checkbox"/> NG , _____
9. Height of Module :	<input type="checkbox"/> Pass	<input type="checkbox"/> NG , _____
10. Others :	<input type="checkbox"/> Pass	<input type="checkbox"/> NG , _____

**3 、 Relative Hole Size :**

1. Pitch of Connector :	<input type="checkbox"/> Pass	<input type="checkbox"/> NG , _____
2. Hole size of Connector :	<input type="checkbox"/> Pass	<input type="checkbox"/> NG , _____
3. Mounting Hole size :	<input type="checkbox"/> Pass	<input type="checkbox"/> NG , _____
4. Mounting Hole Type :	<input type="checkbox"/> Pass	<input type="checkbox"/> NG , _____
5. Others :	<input type="checkbox"/> Pass	<input type="checkbox"/> NG , _____

**4 、 Backlight Specification :**

1. B/L Type :	<input type="checkbox"/> Pass	<input type="checkbox"/> NG , _____
2. B/L Color :	<input type="checkbox"/> Pass	<input type="checkbox"/> NG , _____
3. B/L Driving Voltage (Reference for LED Type) :	<input type="checkbox"/> Pass	<input type="checkbox"/> NG , _____
4. B/L Driving Current :	<input type="checkbox"/> Pass	<input type="checkbox"/> NG , _____
5. Brightness of B/L :	<input type="checkbox"/> Pass	<input type="checkbox"/> NG , _____
6. B/L Solder Method :	<input type="checkbox"/> Pass	<input type="checkbox"/> NG , _____
7. Others :	<input type="checkbox"/> Pass	<input type="checkbox"/> NG , _____

>> Go to page 2 <<

Module Number : \_\_\_\_\_

**5、Electronic Characteristics of Module :**

1.Input Voltage :	<input type="checkbox"/> Pass	<input type="checkbox"/> NG , _____
2.Supply Current :	<input type="checkbox"/> Pass	<input type="checkbox"/> NG , _____
3.Driving Voltage for LCD :	<input type="checkbox"/> Pass	<input type="checkbox"/> NG , _____
4.Contrast for LCD :	<input type="checkbox"/> Pass	<input type="checkbox"/> NG , _____
5.B/L Driving Method :	<input type="checkbox"/> Pass	<input type="checkbox"/> NG , _____
6.Negative Voltage Output :	<input type="checkbox"/> Pass	<input type="checkbox"/> NG , _____
7.Interface Function :	<input type="checkbox"/> Pass	<input type="checkbox"/> NG , _____
8.LCD Uniformity :	<input type="checkbox"/> Pass	<input type="checkbox"/> NG , _____
9.ESD test :	<input type="checkbox"/> Pass	<input type="checkbox"/> NG , _____
10.Others :	<input type="checkbox"/> Pass	<input type="checkbox"/> NG , _____

**6、Summary :**

Sales signature : \_\_\_\_\_

Customer Signature : \_\_\_\_\_

Date : / /